

PRODUCT SPECIFICATIONS

Halsey Taylor Fountain Head, Non-Filtered Non-Refrigerated Stainless. Furnished with Double Bubbler™. Lever Handle activation. Product shall be Wall Mount (On Wall), for Indoor + Outdoor applications, serving 1 station(s). Unit shall be lead-free design which is certified to NSF/ANSI 61 & 372 (lead free) and meets Federal and State low-lead requirements.

| | |
|---------------------------------|------------------------|
| Order ID: | 74025096000 |
| Finish: | Stainless Steel |
| Power: | No Electrical Required |
| Bubbler Style: | Double Bubbler™ |
| Activation by: | Lever Handle |
| Mounting Type: | Wall Mount (On Wall) |
| Chilling Option: | Non-refrigerated |
| Dimensions (L x W x H): | 4" x 2-5/8" x 5-5/8" |
| Approx. Shipping Weight: | 2 lbs. |
| Installation Location: | Indoor + Outdoor |
| No. of Stations Served: | 1 |

- Exclusive Double Bubbler which projects two separate streams that converge to form a fuller, more satisfying drink.



AMERICAN PRIDE. A LIFETIME TRADITION. Like your family, the Elkay family has values and traditions that endure. For almost a century, Elkay has been a family-owned and operated company, providing thousands of jobs that support our families and communities.



Included with Product: Fountain

PRODUCT COMPLIANCE
NSF/ANSI 61 & 372 (lead free)



[Installation Instructions \(PDF\)](#)

Water Systems are warranted for 12 months from date of installation.

Warranty pertains to drinking water applications only. Non-drinking water applications are not covered under warranty.

[Warranty \(PDF\)](#)

PART: _____ QTY: _____

PROJECT: _____

CONTACT: _____

DATE: _____

NOTES: _____

APPROVAL: _____

In keeping with our policy of continuing product improvement, Halsey Taylor reserves the right to change product specifications without notice. Please visit Halseytaylor.com for the most current version of Halsey Taylor product specification sheets. This specification describes a Halsey Taylor product with design, quality, and functional benefits to the user. When making a comparison of other producers' offerings, be certain these features are not overlooked.

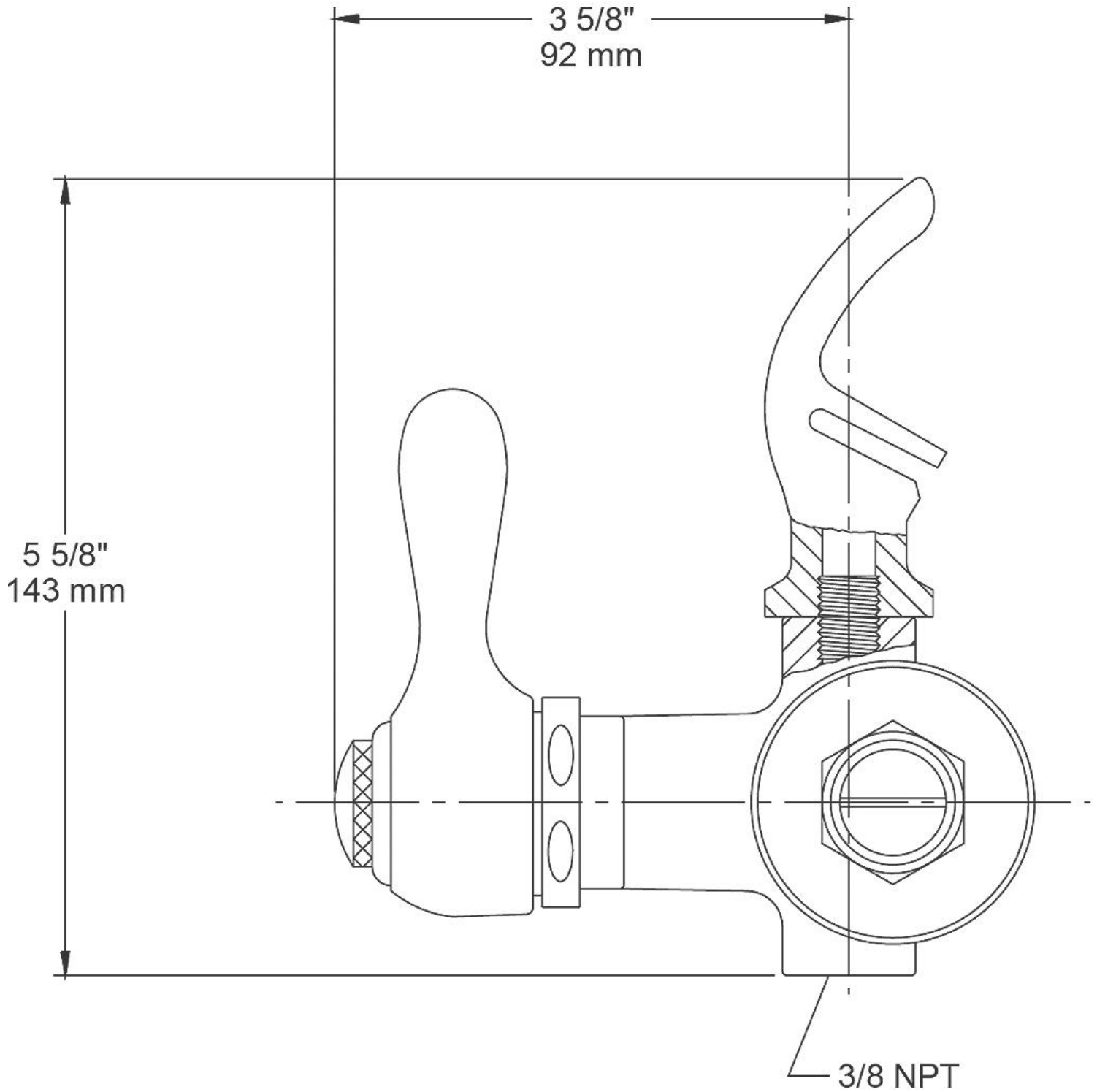

In keeping with our policy of continuing product improvement, Halsey Taylor reserves the right to change product specifications without notice. Please visit Halseytaylor.com for the most current version of Halsey Taylor product specification sheets. This specification describes a Halsey Taylor product with design, quality, and functional benefits to the user. When making a comparison of other producers' offerings, be certain these features are not overlooked.