

**PRODUCT SPECIFICATIONS**

Halsey Taylor Countertop Fountain, Non-Filtered Non-Refrigerated Stainless. Furnished with Pushbutton bubbler. Mechanical Top Bubbler Button activation. Product shall be Countertop mounted, for Indoor/Outdoor applications, serving 1 station(s). Unit shall be lead-free design which is certified to NSF/ANSI 61 & 372 (lead free) and meets Federal and State low-lead requirements.

<b>Order ID:</b>	74100005000
<b>Finish:</b>	Stainless Steel
<b>Power:</b>	No Electrical Required
<b>Bubbler Style:</b>	Pushbutton
<b>Activation by:</b>	Mechanical Top Bubbler Button
<b>Mounting Type:</b>	Countertop
<b>Chilling Option:</b>	Non-Refrigerated
<b>Dimensions (L x W x H):</b>	14-3/8" x 14-3/8" x 10-3/8"
<b>Approx. Shipping Weight:</b>	6 lbs.
<b>Installation Location:</b>	Indoor/Outdoor
<b>No. of Stations Served:</b>	1

- Mechanically-Activated bubbler continues to supply water in event of service disruptions.



AMERICAN PRIDE. A LIFETIME TRADITION. Like your family, the Elkay family has values and traditions that endure. For almost a century, Elkay has been a family-owned and operated company, providing thousands of jobs that support our families and communities.



**Included with Product:** Fountain

**PRODUCT COMPLIANCE**

Buy American Act  
NSF/ANSI 61 & 372 (lead free)



[Installation Instructions \(PDF\)](#)

Water Systems are warranted for 12 months from date of installation. **Warranty pertains to drinking water applications only. Non-drinking water applications are not covered under warranty.**

[Warranty \(PDF\)](#)

**OPTIONAL ACCESSORIES**

HWF172 - WaterSentry VII Filter Kit (Coolers + Fountains)
96852CA - Halsey Taylor Gooseneck Glass Filler Kit

PART: \_\_\_\_\_ QTY: \_\_\_\_\_

PROJECT: \_\_\_\_\_

CONTACT: \_\_\_\_\_

DATE: \_\_\_\_\_

NOTES: \_\_\_\_\_

APPROVAL: \_\_\_\_\_

*In keeping with our policy of continuing product improvement, Halsey Taylor reserves the right to change product specifications without notice. Please visit Halseytaylor.com for the most current version of Halsey Taylor product specification sheets. This specification describes a Halsey Taylor product with design, quality, and functional benefits to the user. When making a comparison of other producers' offerings, be certain these features are not overlooked.*

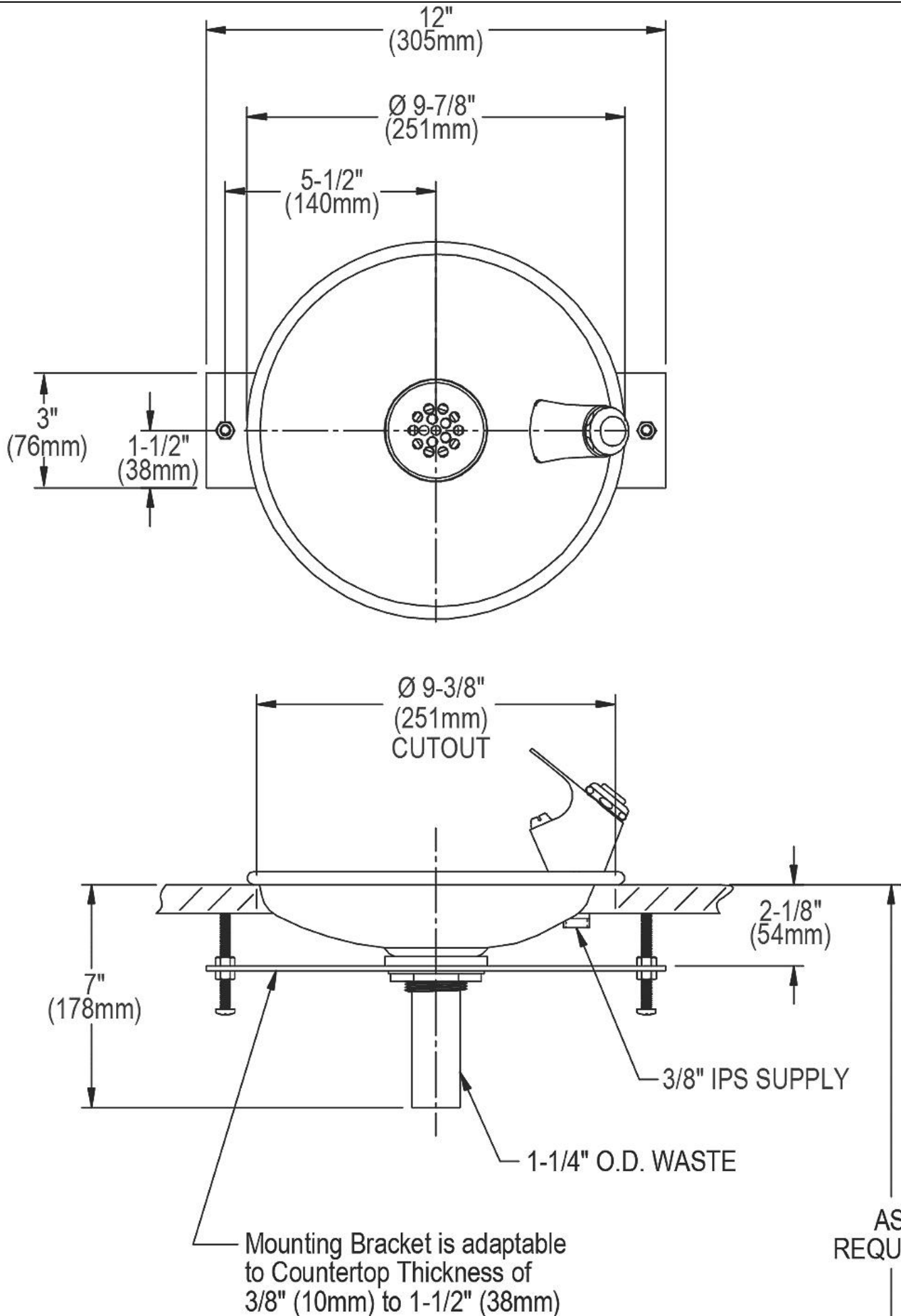

*In keeping with our policy of continuing product improvement, Halsey Taylor reserves the right to change product specifications without notice. Please visit [Halseytaylor.com](http://Halseytaylor.com) for the most current version of Halsey Taylor product specification sheets. This specification describes a Halsey Taylor product with design, quality, and functional benefits to the user. When making a comparison of other producers' offerings, be certain these features are not overlooked.*