

**PRODUCT SPECIFICATIONS**

Halsey Taylor Outdoor Cast Iron Fountain, Non-Filtered Non-Refrigerated Freeze Resistant Forest Green. Features shall include Freeze Resistant. Furnished with Vandal Resistant bubbler. Product shall be Floor Mount/Freestanding, for Outdoor applications, serving 1 station(s). Unit shall be lead-free design which is certified to NSF/ANSI 61 & 372 (lead free) and meets Federal and State low-lead requirements.

<b>Order ID:</b>	76048812161
<b>Special Features:</b>	Freeze Resistant
<b>Finish:</b>	Forest Green
<b>Power:</b>	No Electrical Required
<b>Bubbler Style:</b>	Vandal Resistant
<b>Mounting Type:</b>	Floor Mount/Freestanding
<b>Chilling Option:</b>	Non-refrigerated
<b>Dimensions (L x W x H):</b>	14" x 14" x 40"
<b>Approx. Shipping Weight:</b>	97 lbs.
<b>Installation Location:</b>	Outdoor
<b>No. of Stations Served:</b>	1

- Freeze Resistant:
  - Depending on specific installation, freeze resistant system is located either below frost line or in temperature controlled space.



AMERICAN PRIDE. A LIFETIME TRADITION. Like your family, the Elkay family has values and traditions that endure. For almost a century, Elkay has been a family-owned and operated company, providing thousands of jobs that support our families and communities.



**Included with Product:** Outdoor Fountain

▼ **Ships in multiple boxes.**

**PRODUCT COMPLIANCE**

Buy American Act

NSF/ANSI 61 & 372 (lead free)



[Installation Instructions \(PDF\)](#)

**Warranty pertains to drinking water applications only. Non-drinking water applications are not covered under warranty.**

[Warranty \(PDF\)](#)

PART: \_\_\_\_\_ QTY: \_\_\_\_\_

PROJECT: \_\_\_\_\_

CONTACT: \_\_\_\_\_

DATE: \_\_\_\_\_

NOTES: \_\_\_\_\_

APPROVAL: \_\_\_\_\_

*In keeping with our policy of continuing product improvement, Halsey Taylor reserves the right to change product specifications without notice. Please visit Halseytaylor.com for the most current version of Halsey Taylor product specification sheets. This specification describes a Halsey Taylor product with design, quality, and functional benefits to the user. When making a comparison of other producers' offerings, be certain these features are not overlooked.*

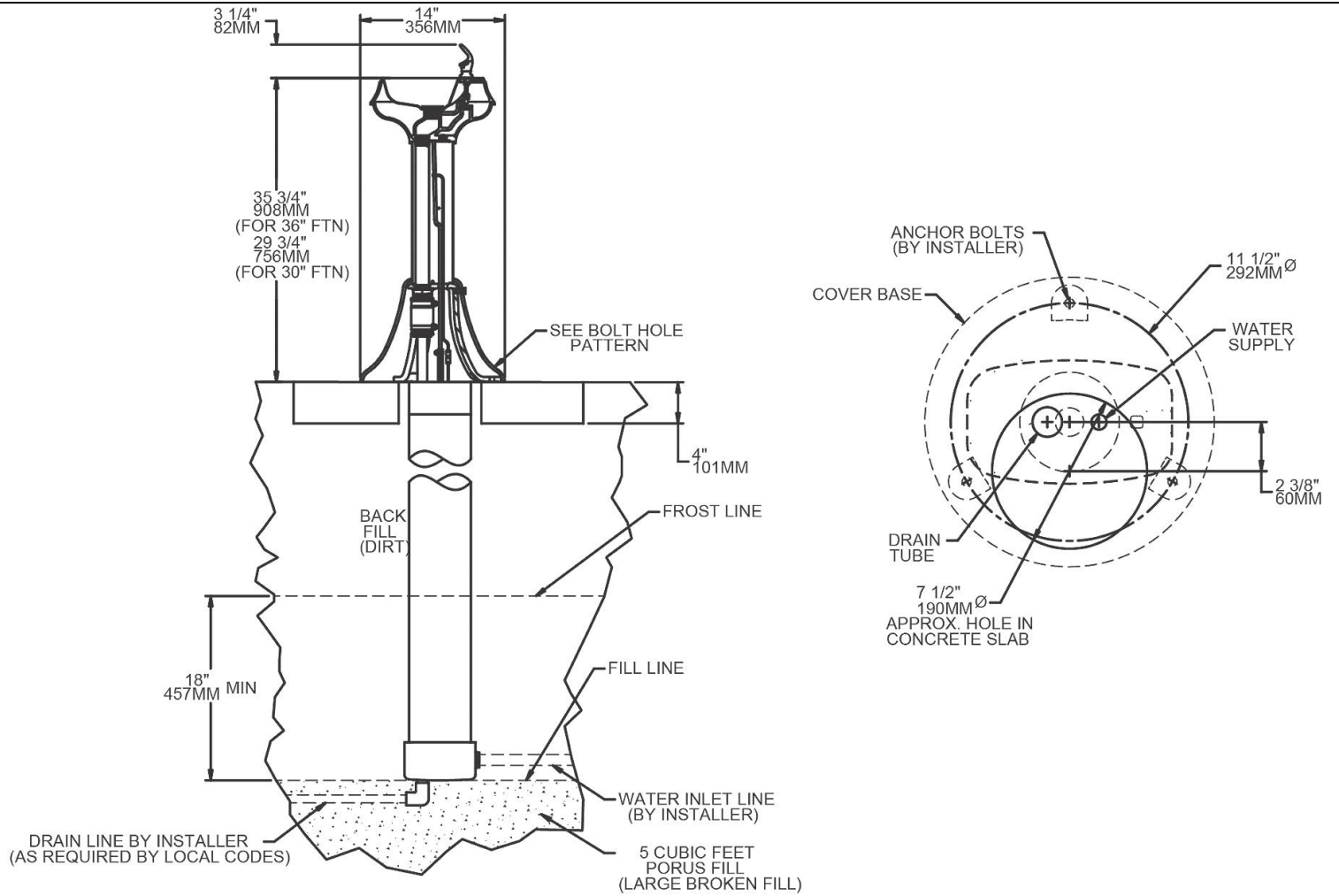

In keeping with our policy of continuing product improvement, Halsey Taylor reserves the right to change product specifications without notice. Please visit [Halseytaylor.com](http://Halseytaylor.com) for the most current version of Halsey Taylor product specification sheets. This specification describes a Halsey Taylor product with design, quality, and functional benefits to the user. When making a comparison of other producers' offerings, be certain these features are not overlooked.