

Installation/Care/Use Manual

Swirlflo® Freeze Resistant Fountain

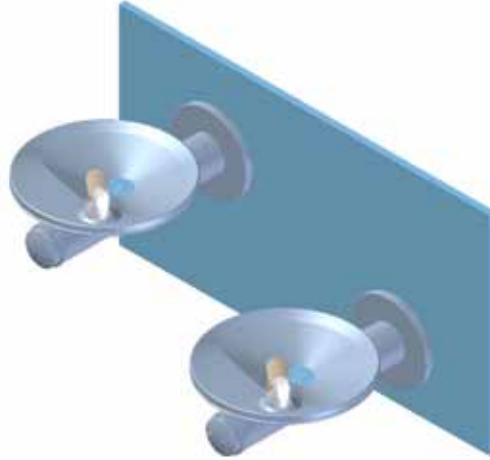

Installer

To assure you install this model easily and correctly, PLEASE READ THESE SIMPLE INSTRUCTIONS BEFORE STARTING THE INSTALLATION. CHECK YOUR INSTALLATION FOR COMPLIANCE WITH PLUMBING, ELECTRICAL AND OTHER APPLICABLE CODES. After installation, leave these instructions with the building owner for future reference. This Freeze Resistant Fountain is shipped in three separate cartons. The second & third carton contains the Freeze Resistant Package **LKFRB1** that is installed on an interior heated wall. Refer to the Freeze Resistant Package for the rough-in dimensions for installation.

IMPORTANT

ALL SERVICE TO BE PERFORMED BY AN AUTHORIZED SERVICE PERSON

IMPORTANT! INSTALLER PLEASE NOTE.

THE GROUNDING OF ELECTRICAL EQUIPMENT SUCH AS TELEPHONE, COMPUTERS, ETC. TO WATER LINES IS A COMMON PROCEDURE. THIS GROUNDING MAY BE IN THE BUILDING OR MAY OCCUR AWAY FROM THE BUILDING. THIS GROUNDING CAN CAUSE ELECTRICAL FEEDBACK INTO A FOUNTAIN, CREATING AN ELECTROLYSIS WHICH CAUSES A METALLIC TASTE OR AN INCREASE IN THE METAL CONTENT OF THE WATER. THIS CONDITION IS AVOIDABLE BY USING THE PROPER MATERIALS AS INDICATED. ANY DRAIN FITTINGS PROVIDED BY THE INSTALLER SHOULD BE MADE OF PLASTIC TO ELECTRICALLY ISOLATE THE FOUNTAIN FROM THE BUILDING PLUMBING SYSTEM.

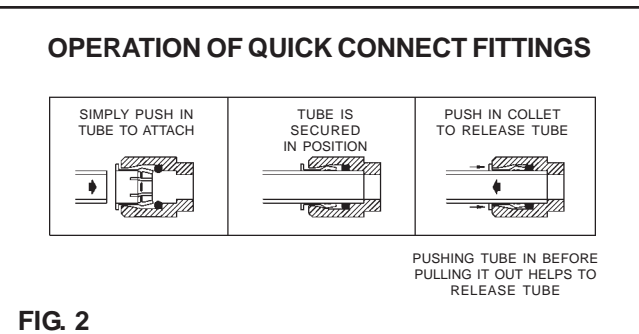
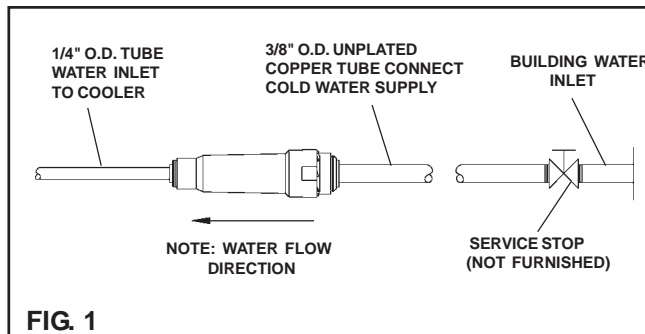

EDFPB(V)M117FPC ROUGH-IN

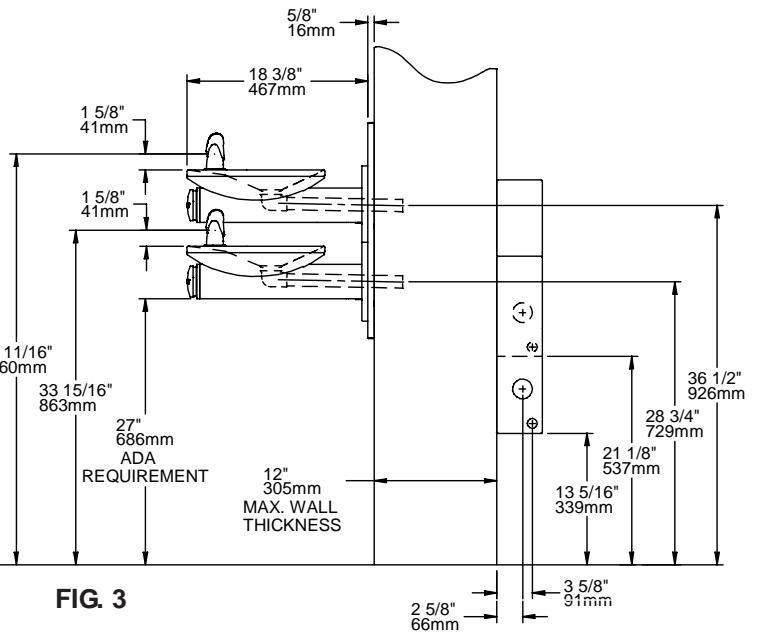
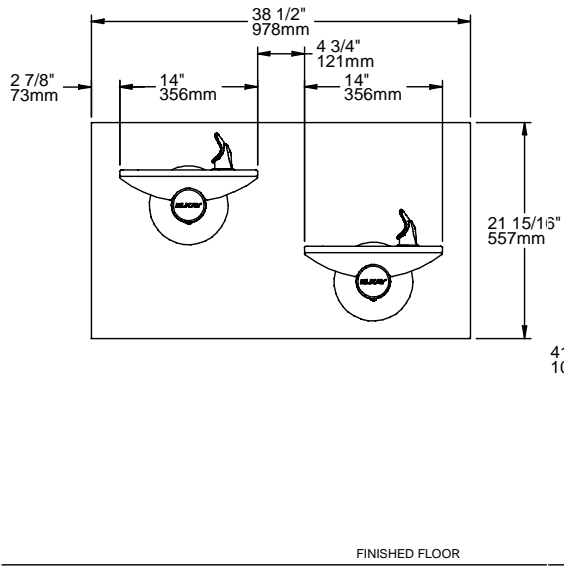
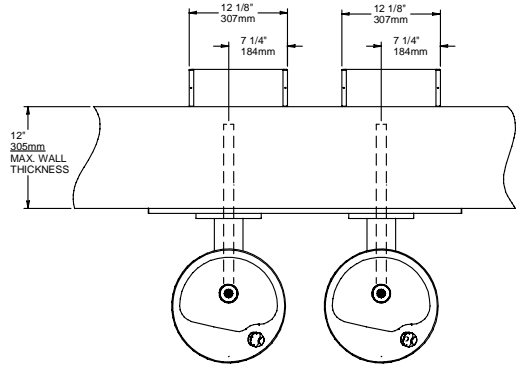
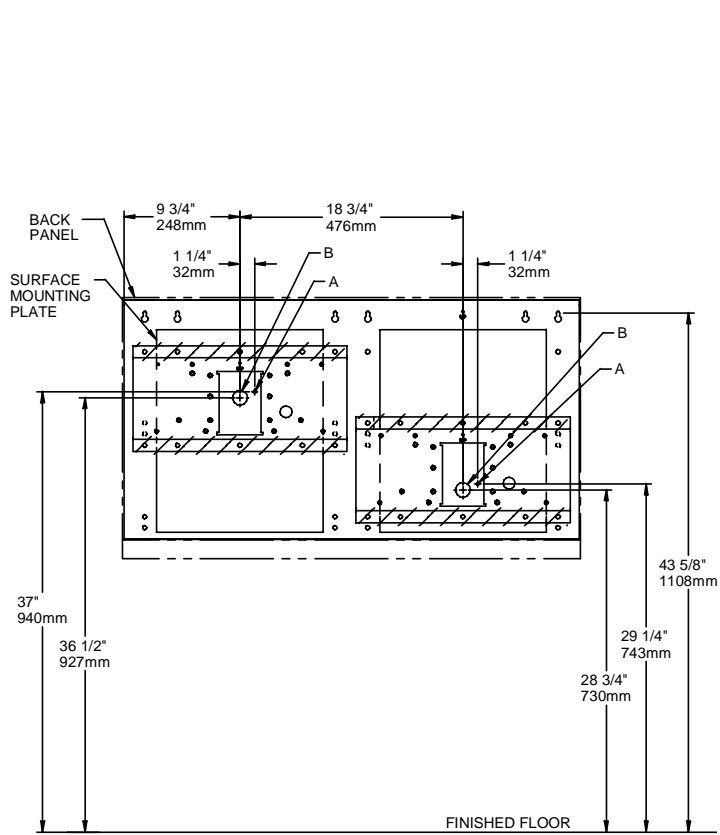

FIG. 3

LEGEND:
 A = 7/8" (22mm) DIA. HOLE FOR WATER SUPPLY TUBE
 B = 1-3/4" (44mm) DIA. HOLE FOR WASTE LINE

NOTE: REINFORCE WALL IN SHADED AREAS.

*Note: All dimensions are taken from the finished floor on the side of the wall that the fountain is installed on.

EDFPB117FPC ROUGH-IN

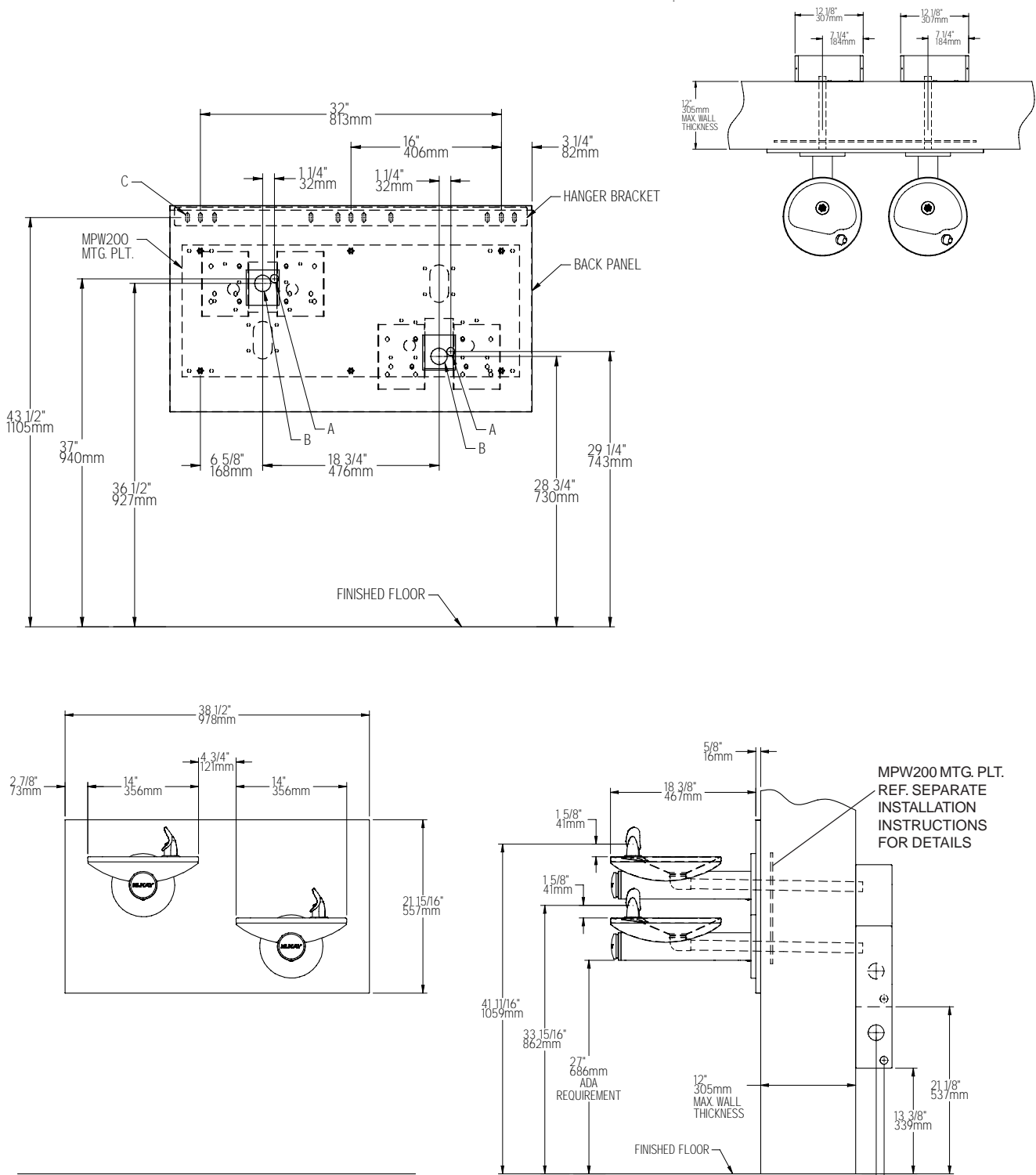

FIG. 4

LEGEND:
A = 7/8" (22mm) DIA. HOLE FOR WATER SUPPLY TUBE
B = 1-3/4" (44mm) DIA. HOLE FOR WASTE LINE
C = 3/8" (10mm) DIA. SLOTS FOR MOUNTING HANGER BRACKET TO WALL

***Note: All dimensions are taken from the finished floor on the side of the wall that the fountain is installed on.**

INSTALLATION INSTRUCTIONS

1. Wall should already be framed for the fountain using the positioning dimensions shown in Fig's. 3, 4, or 5. Shown dimensions pertain to installation location (framing must support up to 300 lbs. weight). These dimensions are required for compliance with ANSI Standard A117.1/ADA requirements.
2. The freeze resistant package must be mounted on an interior wall in a heated area. The room temperature of the interior heated area must be 50° F (10° C) or higher. The freeze resistant package may be surface or recessed mounted. If recess mounted the surface of the cover must be flush with the interior wall surface. The package is furnished with screws for mounting the cover to the box. If the box is recess mounted, do not fasten the top and bottom of the cover to the box. Use the holes on the front only.
3. To assemble the operating cable to the sleeve inside the fountain arm you will need to remove cap screw (Item 18, See Fig. 6) and then remove Push Button and Pin (Items 12 & 13, See Fig. 6). Remove screw (Item 20, See Fig. 6) and you will now be able to remove the Sleeve (Item 7, See Fig. 6) to get access to the adjustment nuts for additional adjustability. (Fountain should be mounted to exterior wall) Create a loop in the cable and thread the free end of the cable through the wall into the freeze resistant box. The adjustment nuts should be in the middle of threaded area on the operating cable. See Fig. 6.
4. Connect free end of operating cable to the valve-operating bracket. The end of the cables must be recessed into the indents on the pivot brackets.
5. Remove cable free play by adjusting the jam nuts on the ends of the operating cable. See Fig. 6.
6. Connect water line from fountain bubbler into freeze resistant box. The connection to the box uses a quick connect water fitting. Position the water line, in the fountain, to drain back into interior mounted box. Any water left standing, in the exterior line, can freeze. To insure positive draining of the bubbler supply tube, excess length should be trimmed off and discarded.
7. Connect drain and water supply lines to the freeze resistant fountain. Inline strainer must be used on the inlet water line.

START UP

1. Turn on building water supply and check all connections for leaks. Repair as required.
2. Stream height is factory set at 35 PSI. If stream height needs to be changed adjust the regulator in the freeze resistant package. Clockwise adjustment raises stream height, counter clockwise adjustment will lower stream.
3. Adjust operating cable as required. Cable system should have a minimal amount of free play to allow for proper valve operation. If the system is too tight the valve will stay in the on position creating constant water flow. Too much free play will result in non-operation of the valve with the push-buttons.
4. **Note:** Water from the drain back tube in the freeze resistant package will continue to run while the valve is actuated.
5. After cable system is adjusted properly, stuff flexible insulation into any openings between the outside wall and the interior box.
6. Recheck all connections. If all connections are leak free replace cover(s) on the freeze resistant box(es) and fountain(s).

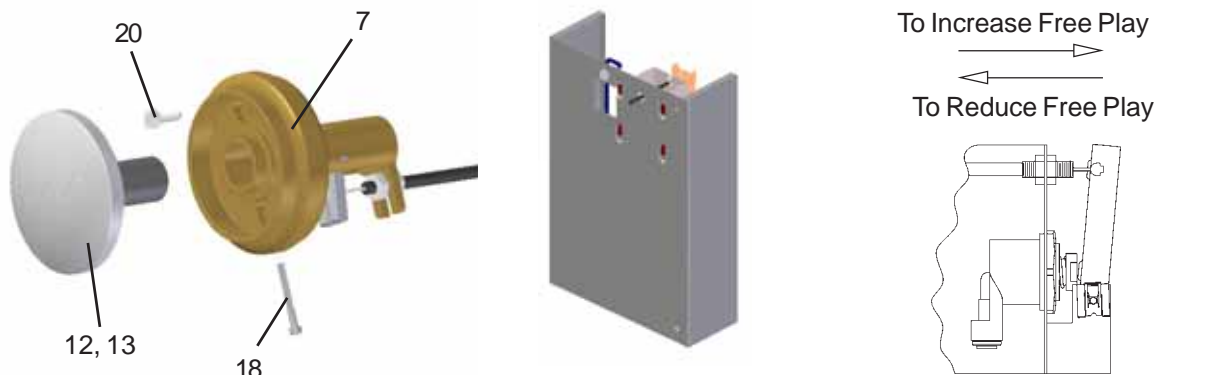
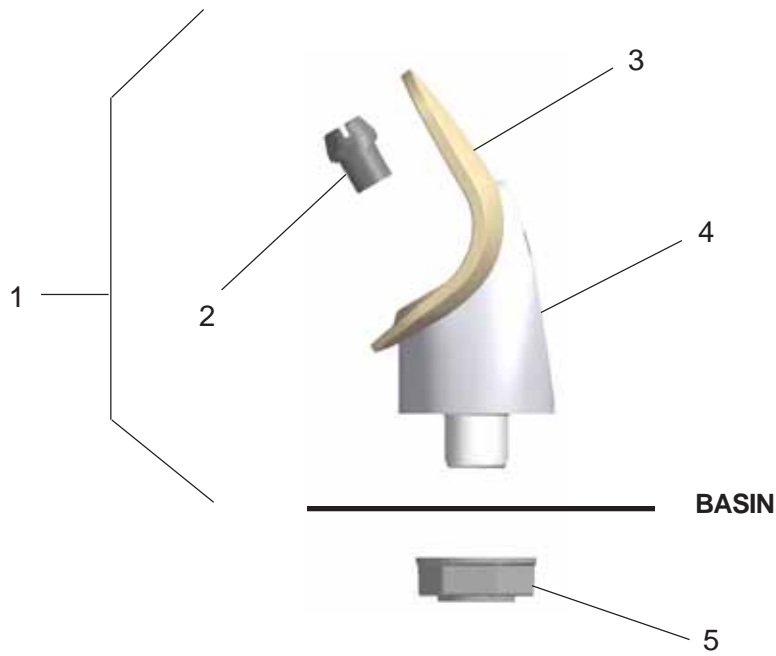

FIG. 6



NOTE:

When installing replacement bubbler and pedestal, tighten nut (Item 5) only to hold parts snug in position. Do Not Over-tighten.

Bubbler Details

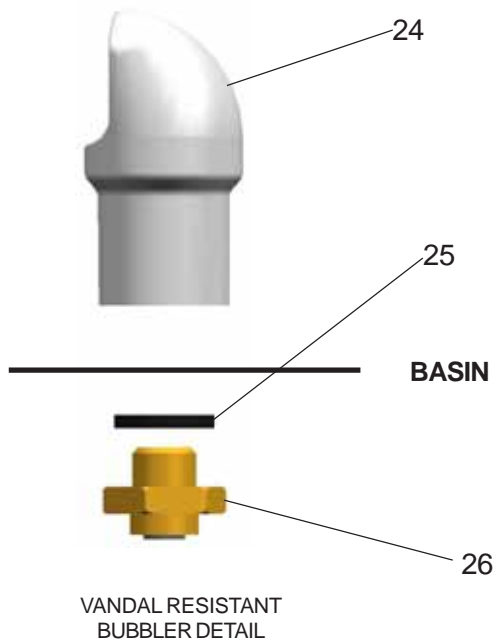

**VANDAL RESISTANT
BUBBLER DETAIL**

FIG. 7 - Bubbler Details

PARTS LIST		
ITEM NO.	PART NO.	DESCRIPTION
1	56073C	Bubbler Assy
2	40322C	Orifice Assy
3	56011C	Housing Assembly
4	55997C	Pedestal
5	75580C	Bubbler Locknut
6	15027C	Brkt - Swirlflow
7	15025C	Assy - Sleeve/Button Swirlflo
8	28474C	Basin - Swirlflow
9	28473C	Lower Shell
10	45767C	Fountain Body
11	28343C	Cover Plate
12	45848C	Button - Push Swirlflo
13	45821C	Pin - Push Button Swirlflo FP
14	56163C	Gasket - Drain
15	45769C	Assy - Drain/Tailpipe
16	45768C	Drain - Plug 1-1/2"
17	56092C	Poly Tubing (Cut To Length)
18	75669C	Cap Screw - #6-32 x 1.25"
19	70817C	Fitng - Elbow 1/4 x 1/4
20	111008343890	Screw - #10-24 x .62 HHSM
21	28392C	Panel - Back RH ADA
	28393C	Panel - Back LH ADA
22	70432C	Screw - #8-32 x .38 THMS
23	75560C	Screw - 5/16-18 x1.00 HHMS
24	98118C	Bubbler Assembly VR
25	100322740560	Gasket - Black .68 x 1.03 VR
26	15009C	Nipple - Bubbler VR
27	28844C	Back Panel Assy. RH ADA
	28845C	Back Panel Assy. LH ADA
NS	27090C	Hanger Bracket

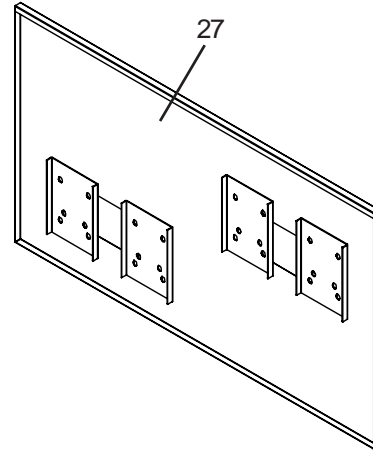

FIG. 8

Installing Back Panel: When installing back panel assy. (Item 27) with MPW (Mounting Plate), attach channel braces as shown above. Remove the protective backing from the tape installed on the braces. Line up the corresponding holes in the braces and back panel and press firmly in place.

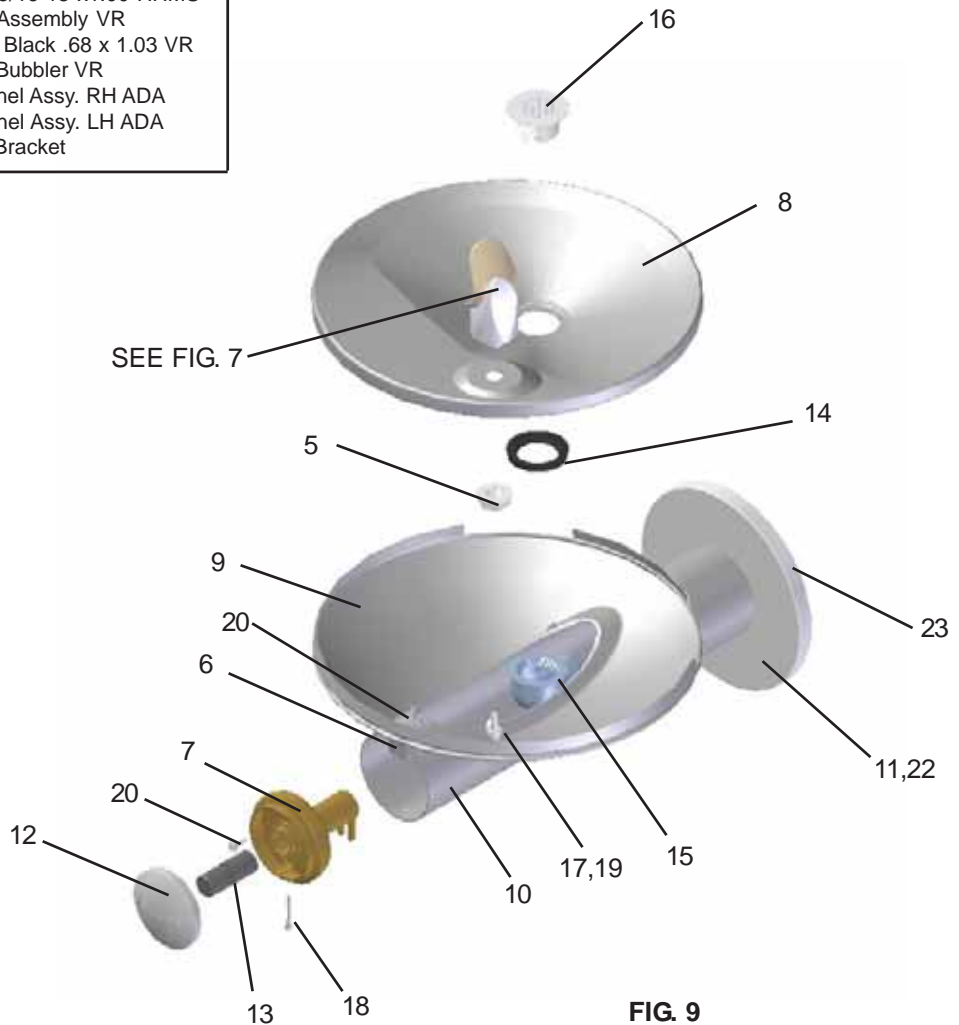

FIG. 9

FOR PARTS, CONTACT YOUR LOCAL DISTRIBUTOR OR CALL 1.800.323.0620
 ELKAY MANUFACTURING COMPANY • 2222 CAMDEN COURT • OAK BROOK, IL 60523 • 630.574.8484