

PRODUCT SPECIFICATIONS

Elkay Soft Sides® Multi-Station Composite Fountain Non-Filtered, Non-Refrigerated White Granite Composite. Furnished with Vandal Resistant bubbler. Mechanical Front Bubbler Button activation. Product shall be Wall Mount (On Wall), for Indoor + Outdoor applications, serving 3 station(s). Unit shall be lead-free design which is certified to NSF/ANSI 61 & 372 (lead free) and meets Federal and State low-lead requirements.

Finish:	White Granite Composite (WHT)
Power:	No Electrical Required
Bubbler Style:	Vandal Resistant
Activation by:	Mechanical Front Bubbler Button
Mounting Type:	Wall Mount (On Wall)
Chilling Option:	Non-refrigerated
Dimensions (L x W x H):	58-1/2" x 18-1/16" x 8"
Approx. Shipping Weight:	126 lbs.
Installation Location:	Indoor + Outdoor
No. of Stations Served:	3

- Mechanically-Activated bubbler continues to supply water in event of service disruptions.
- With a contemporary look and smooth, rounded lines, these wall mounted drinking fountains are constructed of a premium composite, solid surface material.



AMERICAN PRIDE. A LIFETIME TRADITION. Like your family, the Elkay family has values and traditions that endure. For almost a century, Elkay has been a family-owned and operated company, providing thousands of jobs that support our families and communities.



Included with Product: Fountain

PRODUCT COMPLIANCE

ADA & ICC A117.1

Buy American Act

NSF/ANSI 61 & 372 (lead free)



Complies with ADA & ICC A117.1 accessibility requirements when installed according to the requirements outlined in these standards. Installation may require additional components and/or construction features to be fully compliant. Consult the local Authority Having Jurisdiction if necessary.

[Installation Instructions \(PDF\)](#)

Water Systems are warranted for 12 months from date of installation.

Warranty pertains to drinking water applications only. Non-drinking water applications are not covered under warranty.

[Warranty \(PDF\)](#)

OPTIONAL ACCESSORIES

AP99 - Elkay Access Panel 9" x 9" x 6"
ACCESS12X38-5 - Accessory - Access Panel for Gray ABS Plastic
98481C - Accessory - Bubbler Kit Water-Efficient Vandal-Resistant
EWf172 - WaterSentry VII Filter Kit (Coolers + Fountains)

PART: _____ QTY: _____

PROJECT: _____

CONTACT: _____

DATE: _____

NOTES: _____

APPROVAL: _____

In keeping with our policy of continuing product improvement, Elkay reserves the right to change product specifications without notice. Please visit elkay.com for the most current version of Elkay product specification sheets. This specification describes an Elkay product with design, quality, and functional benefits to the user. When making a comparison of other producers' offerings, be certain these features are not overlooked.

INSTALLER NOTE

This drinking fountain is furnished with a bubbler and valve including all connecting fittings which are manufactured of completely lead free material. Shut off valve (not furnished) to accept 3/8" O.D. unplated copper tube.

OPERATION OF QUICK CONNECT FITTINGS

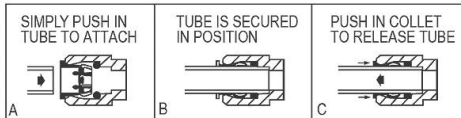

PUSHING TUBE IN BEFORE PULLING IT OUT HELPS TO RELEASE TUBE

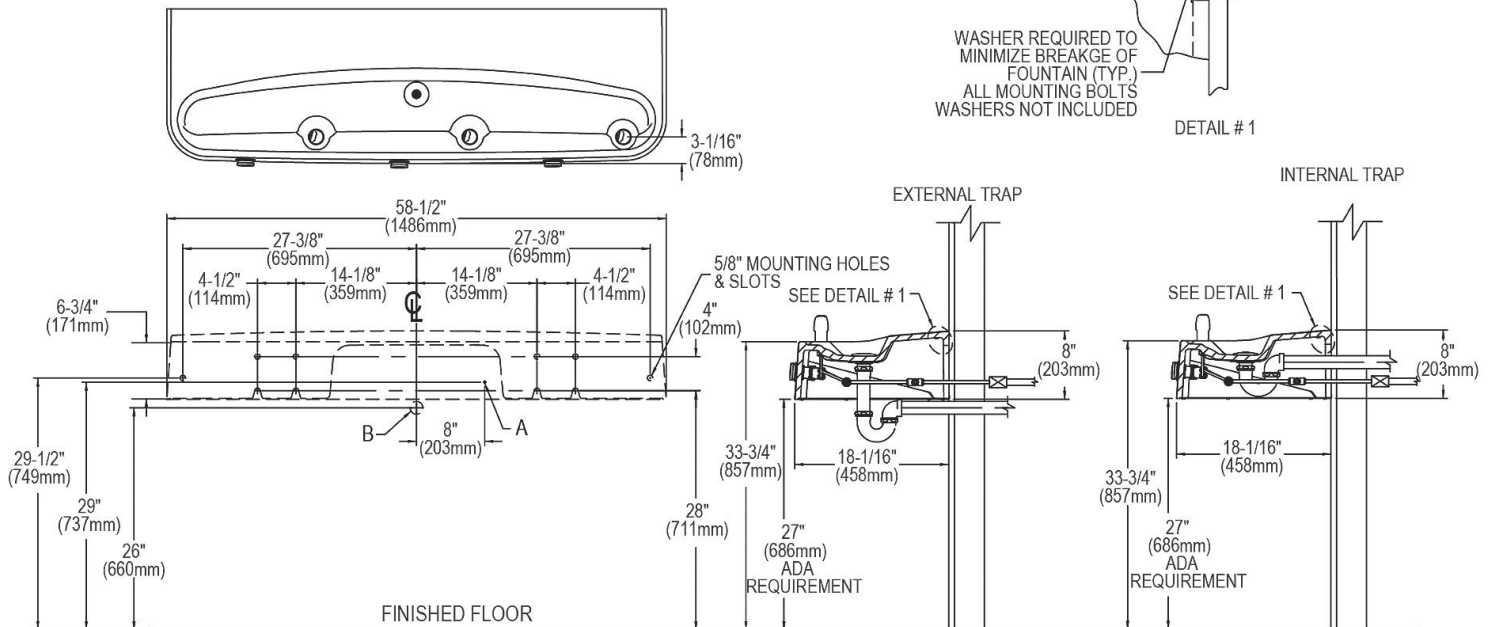
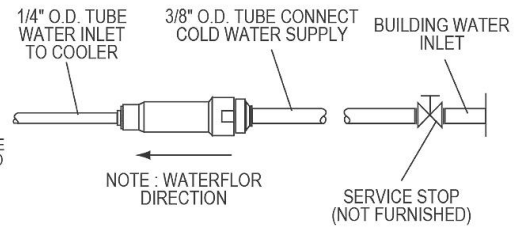

WASHER REQUIRED TO MINIMIZE BREAKAGE OF FOUNTAIN (TYP.) ALL MOUNTING BOLTS WASHERS NOT INCLUDED

DETAIL # 1

LEGEND

A = 3/8" O.D. Unplated copper tube connect - shut off valve by others
B = Water outlet 1-1/2" O.D. drain stub out from wall 1" (25mm)

In keeping with our policy of continuing product improvement, Elkay reserves the right to change product specifications without notice. Please visit elkay.com for the most current version of Elkay product specification sheets. This specification describes an Elkay product with design, quality, and functional benefits to the user. When making a comparison of other producers' offerings, be certain these features are not overlooked.