

PRODUCT SPECIFICATIONS

Elkay Soft Sides® Multi-Station Composite Fountain Non-Filtered, Non-Refrigerated Freeze Resistant White Granite Composite. Features shall include Freeze Resistant. Furnished with Vandal Resistant bubbler. Mechanical Front Bubbler Button activation. Product shall be Wall Mount (On Wall), for Indoor + Outdoor applications, serving 3 station(s). Unit shall be lead-free design which is certified to NSF/ANSI 61 & 372 (lead free) and meets Federal and State low-lead requirements.

Special Features:	Freeze Resistant
Finish:	White Granite Composite (WHT)
Power:	No Electrical Required
Bubbler Style:	Vandal Resistant
Activation by:	Mechanical Front Bubbler Button
Mounting Type:	Wall Mount (On Wall)
Chilling Option:	Non-refrigerated
Dimensions (L x W x H):	58-1/2" x 18-1/16" x 8"
Approx. Shipping Weight:	152 lbs.
Installation Location:	Indoor + Outdoor
No. of Stations Served:	3

- Mechanically-Activated bubbler continues to supply water in event of service disruptions.
- With a contemporary look and smooth, rounded lines, these wall mounted drinking fountains are constructed of a premium composite, solid surface material.
- Freeze Resistant:
- Depending on specific installation, freeze resistant system is located either below frost line or in temperature controlled space.



AMERICAN PRIDE. A LIFETIME TRADITION. Like your family, the Elkay family has values and traditions that endure. For almost a century, Elkay has been a family-owned and operated company, providing thousands of jobs that support our families and communities.



Included with Product: Fountain, Freeze Resistant Valve Assembly

▼ Ships in multiple boxes.

PRODUCT COMPLIANCE

ADA & ICC A117.1
Buy American Act
NSF/ANSI 61 & 372 (lead free)



Complies with ADA & ICC A117.1 accessibility requirements when installed according to the requirements outlined in these standards. Installation may require additional components and/or construction features to be fully compliant. Consult the local Authority Having Jurisdiction if necessary.

[Installation Instructions \(PDF\) - 98479C](#)
[Installation Instructions \(PDF\) - 98484C](#)

Water Systems are warranted for 12 months from date of installation. **Warranty pertains to drinking water applications only. Non-drinking water applications are not covered under warranty.**
[Warranty \(PDF\)](#)

OPTIONAL ACCESSORIES

AP99 - Elkay Access Panel 9" x 9" x 6"
ACCESS12X38-5 - Accessory - Stainless Steel Access Panel for Bi-Level Architectural Fountains
98481C - Accessory - Bubbler Kit Water-Efficient Vandal-Resistant
EWV172 - WaterSentry VII Filter Kit (Coolers + Fountains)

PART: _____ QTY: _____
PROJECT: _____
CONTACT: _____
DATE: _____
NOTES: _____
APPROVAL: _____

In keeping with our policy of continuing product improvement, Elkay reserves the right to change product specifications without notice. Please visit elkay.com for the most current version of Elkay product specification sheets. This specification describes an Elkay product with design, quality, and functional benefits to the user. When making a comparison of other producers' offerings, be certain these features are not overlooked.

INSTALLER NOTE

This drinking fountain is furnished with a bubbler and valve including all connecting fittings which are manufactured of completely lead free material. Shut off valve (not furnished) to accept 3/8" O.D. unplated copper tube.

OPERATION OF QUICK CONNECT FITTINGS

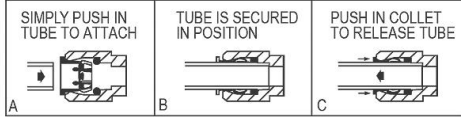

PUSHING TUBE IN BEFORE PULLING IT OUT HELPS TO RELEASE TUBE

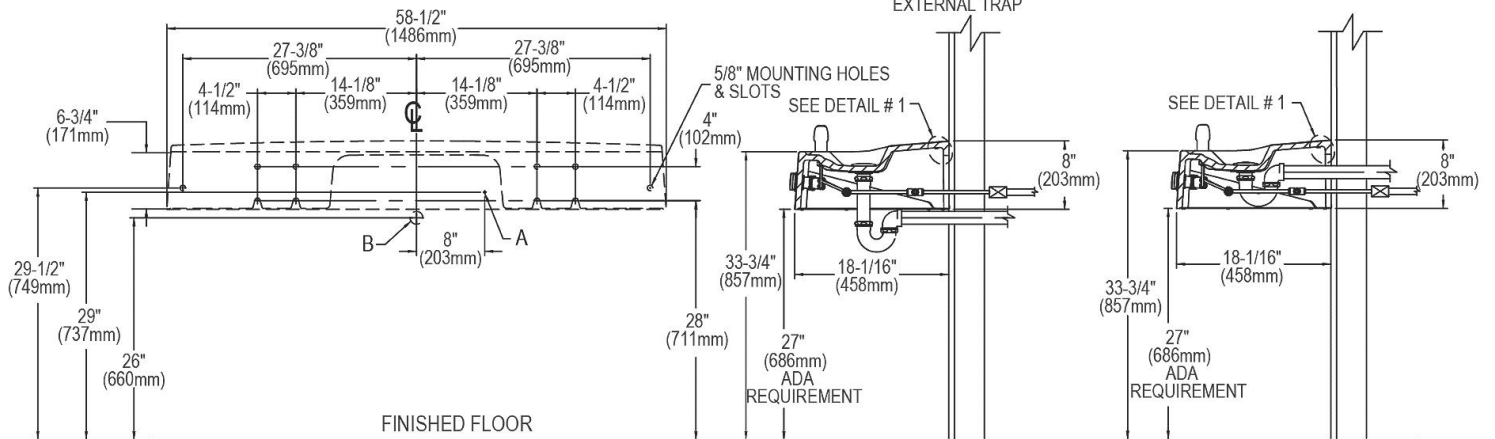
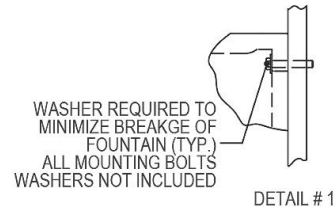
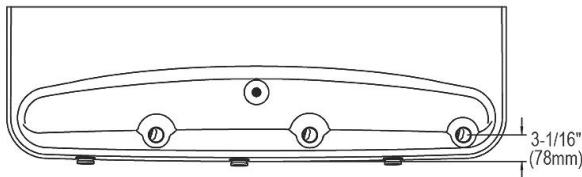
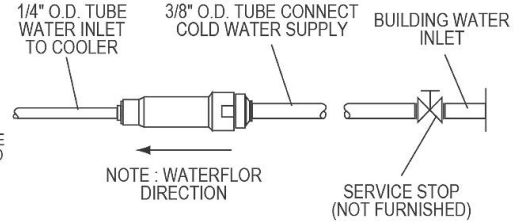

LEGEND

A = 3/8" O.D. Unplated copper tube connect - shut off valve by others
B = Water outlet 1-1/2" O.D. drain stub out from wall 1" (25mm)

In keeping with our policy of continuing product improvement, Elkay reserves the right to change product specifications without notice. Please visit elkay.com for the most current version of Elkay product specification sheets. This specification describes an Elkay product with design, quality, and functional benefits to the user. When making a comparison of other producers' offerings, be certain these features are not overlooked.